

# BREVA

SONIC MACHINERY

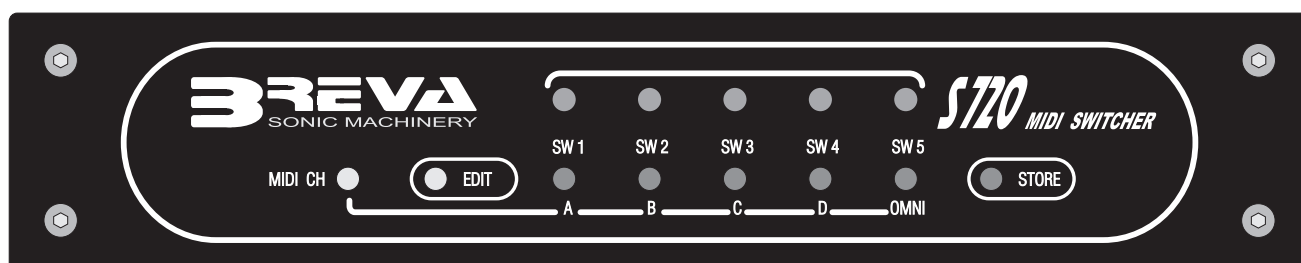

## *S720* **MIDI SWITCHER**

STATIC OR MOMENTARY PROGRAMMABLE MODE

*USER MANUAL*

# Characteristics

S720 is a multiple MIDI switcher incorporates the functions of 5 pure switches - suitable for the ON/OFF management of remote control devices (for example the change of amplifier channel, by-pass effects, step controls, etc.)

The switches can be set independently in three different modes:

- 1) STATIC
- 2) MOMENTARY A
- 3) MOMENTARY B

In the **STATIC** mode the switch works as a normal switch (ON/OFF): the contact is ON when selected and OFF when deselected, following the trend of its corresponding visualization led (RED).

In the **MOMENTARY A** mode the switch works as a switch (ON/ON): the contact is on when selected, only for approx. 50ms, then automatically goes to OFF. The corresponding visualization led (GREEN) remains active to indicate the selection.

In the **MOMENTARY B** mode (yellow led) the switch work as in the A mode: the only difference is that the contact is ON in correspondence of the location access and then in correspondance of the output. This permits to utilize S720 to control the electronic by-pass devices (with push-button) in the same way as for most of the NON TRUE BYPASS effect pedals (See dedicated section).

**\*\*Never connect S720 to power signals (i.e. Audio power amps, speaker out, etc)**

## MIDI MANAGEMENT

S720 is managed via MIDI through a pedal board, a sequencer or a MIDI device able to send messages of program change according to MIDI standard.

It consist of one MIDI IN, one MIDI THRU, and thanks to the 7 poles connector, it can be powered through phantom power.

Memorization on 128 memory locations (presets).

Programming of MIDI receiving channel (from 1 to 16).

## CASCADE CONNECTION

It is possible to connect more than one S720, also combined with other MIDI devices, through MIDI IN and MIDI THRU connections.

## “FREE”/ RACK ASSEMBLAGE

S720 can be used in its “free format”, fixed on the floor with a VELCRO or with an optional panel RP2 RACKMOUNT, mounted on rack 19”. RP2 can sustain one or two S720 or other devices produced by BREVA SONIC MACHINERY having the same size (LS42).



**DIMENSIONS :** mm 212 x 112 x 44

**WEIGHT :** g 500

**POWER SUPPLY :** 9VCC 500mA / with standard 2,5mm coaxial plug

**SWITCH CONNECTIONS :** standard JACK 1/4"

**MIDI CONNECTIONS :** standard DIN 5 / 7 poli

**AUX CONNECTIONS :** standard SUB-D 15 poli

# Programming

When turned on, S720 performs the starting test showing in sequence the 5 switches visualization leds Differently coloured according to the following three modes:

STATIC - RED  
MOMENTARY A - GREEN  
MOMENTARY B - YELLOW

After 7 seconds the devices will set on SWITCHER mode, on preset "00", showing the chosen mode or the selection.

## MODE SETTING

- 1) Push EDIT button, the five leds will flash rapidly.
- 2) Push many times each of the buttons in order to choose the mode(red, green or yellow).  
Anyone of the 5 switches can be set independently. This setup will result the same for all the 128 presets.
- 3) In order to memorize, wait for 5 seconds or push EDIT once more.

S720 will return on SWITCHER condition.

## PRESET SETTING

Connecting a MIDI pedal ( or another program changer) to MIDI IN, it is possible to go through the other presets (from 00 to 127):

- 1) Recall a preset from the pedal board
- 2) Select the desired switches
- 3) Push STORE button

Repeat these 3 steps to programm the other presets.

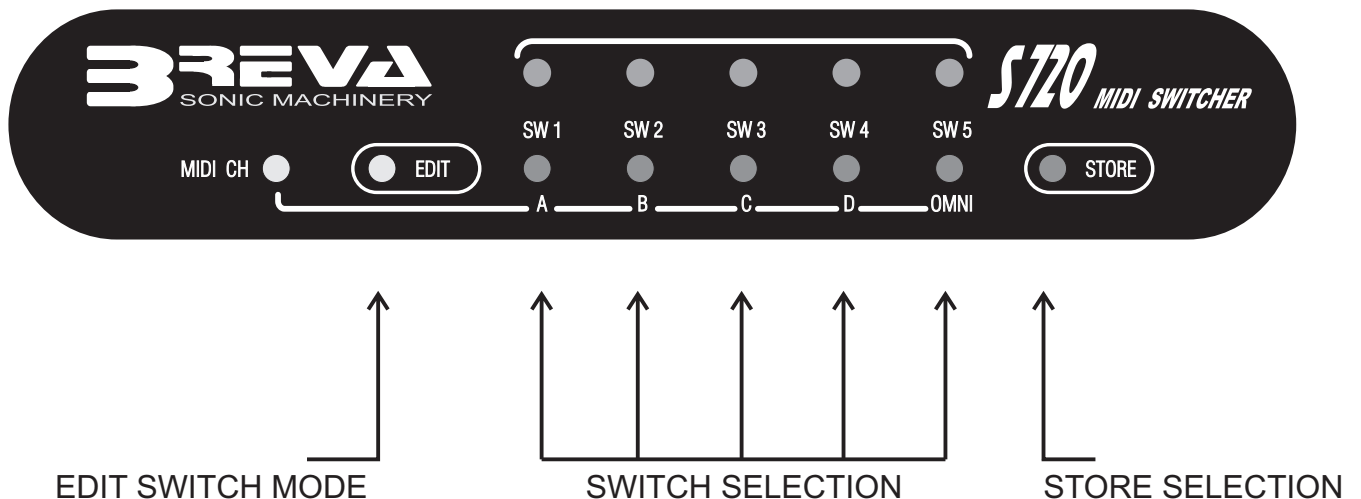

# MOMENTARY MODE “A” and “B”

## MOMENTARY MODE “A”

This mode (green led) reproduces the behaviour of a push button, that is the behaviour of a contact which closes for a second and then reopens.

A typical example is the control of a head amplifier with CLEAN/CRUNCH/LEAD having the pedal composed by three buttons, with annexed digital logic, working in exclusion (only a channel is active, pushing another button it is possible to exclude the previous one etc.).

With three switches of S720 set on MOMENTARY A it is possible to control via MIDI the activation of 3 channels.

The contact is activated only once, when selected (green led on); pushing more times, the contact does not repeat the operation unless the command is not coming from another preset.

## MOMENTARY MODE “B”

This mode (yellow led) reproduces the behaviour of a push button as described in MODE A, with the difference that the button is activated also in correspondence of the output of the preset.

This function is necessary to control ON/ON push buttons.

The typical example is the management of a head amplifier when this one is controlled through a key, with digital logic annexed.

A very interesting application of this functionality is the one combined to pedal effects NON TRUEBYPASS, having analogic switch transistor with push-button control.

With a small change, easy and irreversible, it is possible to adapt most of these pedal effects to be utilized with S720 in order to manage the activation via MIDI.

To recognise the suitable models it is necessary to go through the pedal box and be sure of switch button is used. Generally on the push button there are two contacts from which two conductors goes through the circuit.

Using a normal tester, go on these two contacts and, acting on the push button, verify that it is a momentaneous contact, that closes pushing the button and reopening releasing it.

At this point soft-solder two conductor, with a lenght sufficient to reach S720, exactly in parallel to the push button contacts.

Recognise an way through the box, insert the two conductors, then close the pedal again.

Verify that the operation is ok turning on the pedal inserting the jack and making contact between the two conductors: the bypass must work and will be pointed out by the led.

At this point soft-solder the ends of the two conductors respectively at the point and at the body of a jack connector 1/4". Connected the jack at S720 and then verify the correct functioning.

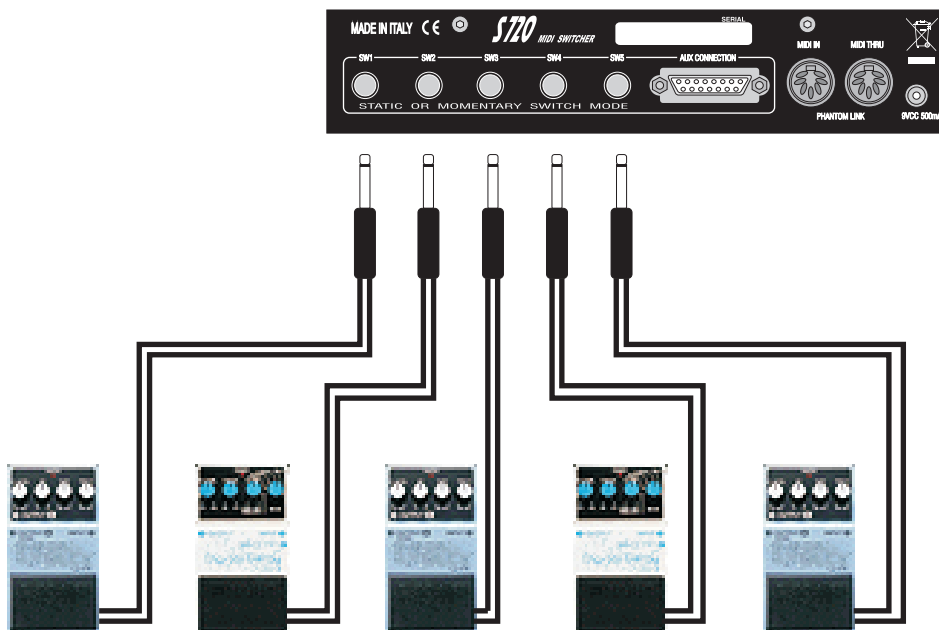

# SWITCHES CONNECTION

Each one of the 5 switches consist of exchange contacts switches; in this way, 2 contacts are available for each switch: normally open (NO) and normally closed (NC).

In order to reach the two contacts (NO and NC) it is necessary to use an external jack which ends in two mono jacks, as represented in the following pictures.

In order to utilize only one contact (NO) it is sufficient to have a normal mono jack cable.

There are some situations where, with one switch only, (static mode) it is possible to control two devices, for exemple two devices that must be activated exclusively in a complementary way (A=On, B=Off or A=Off, B=On).

Each contact of the 5 switches, besides being connected to the jack outputs, is available also on a SUB-D 15 poles plug. The contacts are reported in parallel and the aim is to assemble in a sole connector all the connections. The connections disposition does not refer to anyone of the existing standard, so that it is necessary to realize the cable. It could also refer only to a part of the contacts, observing the scheme below.

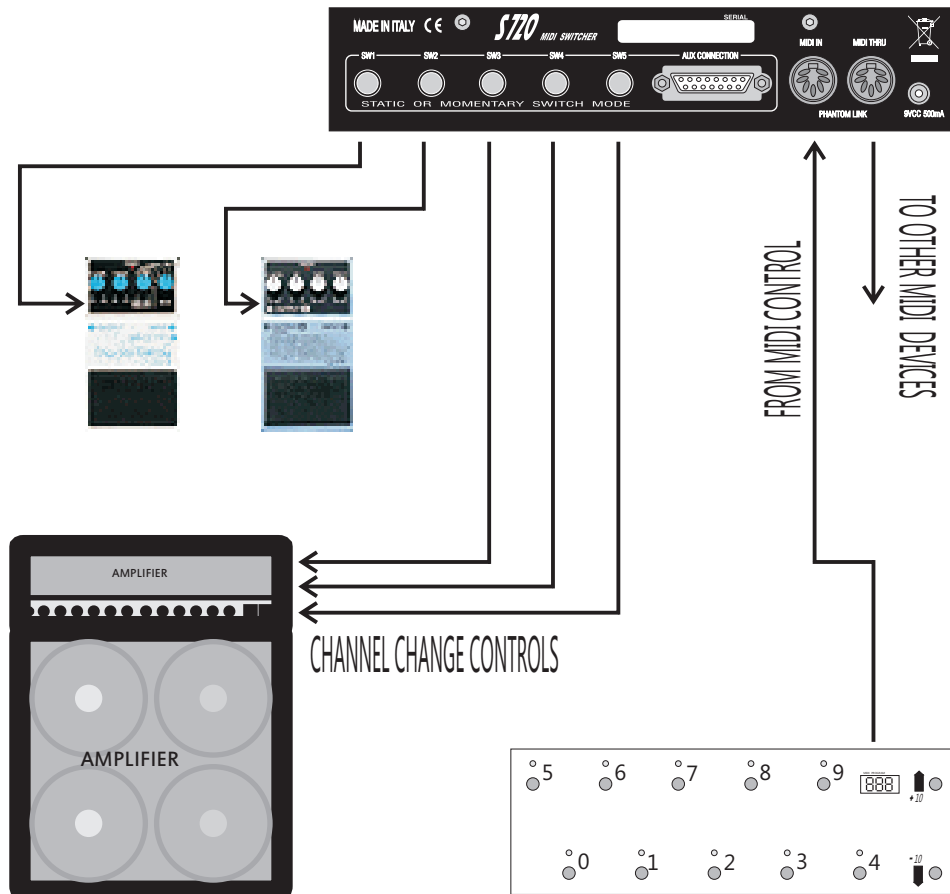
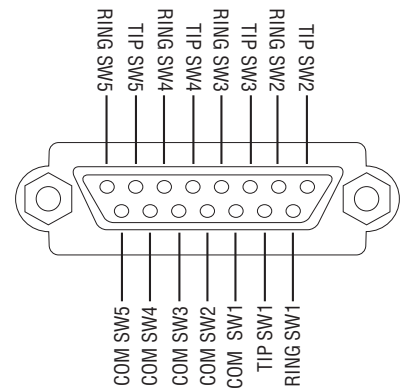
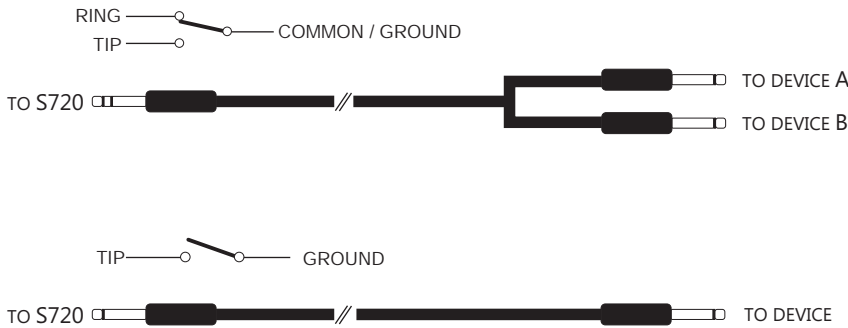

# MIDI Setup

The programming of the MIDI SETUP is simple and intuitive.

Pressing the button MIDI CH, he activates the way MIDI SETUP : the green leds flash.

Pressing the button OMNI, all the leds flash and S720 receives on all the 16 MIDI channels.

Still pressing on OMNI, S720 returns the normal formality (1 ...16).

To select the channel MIDI (1 ...16),  
to follow to the scheme brought in the underlying chart.

|    | A | B | C | D |    | A | B | C | D |
|----|---|---|---|---|----|---|---|---|---|
| 01 | ○ | ○ | ○ | ○ | 09 | ○ | ○ | ○ | ● |
| 02 | ● | ○ | ○ | ○ | 10 | ● | ○ | ○ | ● |
| 03 | ○ | ● | ○ | ○ | 11 | ○ | ● | ○ | ● |
| 04 | ● | ● | ○ | ○ | 12 | ● | ● | ○ | ● |
| 05 | ○ | ○ | ● | ○ | 13 | ○ | ○ | ● | ● |
| 06 | ● | ○ | ● | ○ | 14 | ● | ○ | ● | ● |
| 07 | ○ | ● | ● | ○ | 15 | ○ | ● | ● | ● |
| 08 | ● | ● | ● | ○ | 16 | ● | ● | ● | ● |

After having chosen the desired setup, to again press MIDI CH, or to attend some second: S720 returns in the modality "SWITCHER" memorizing the setup.

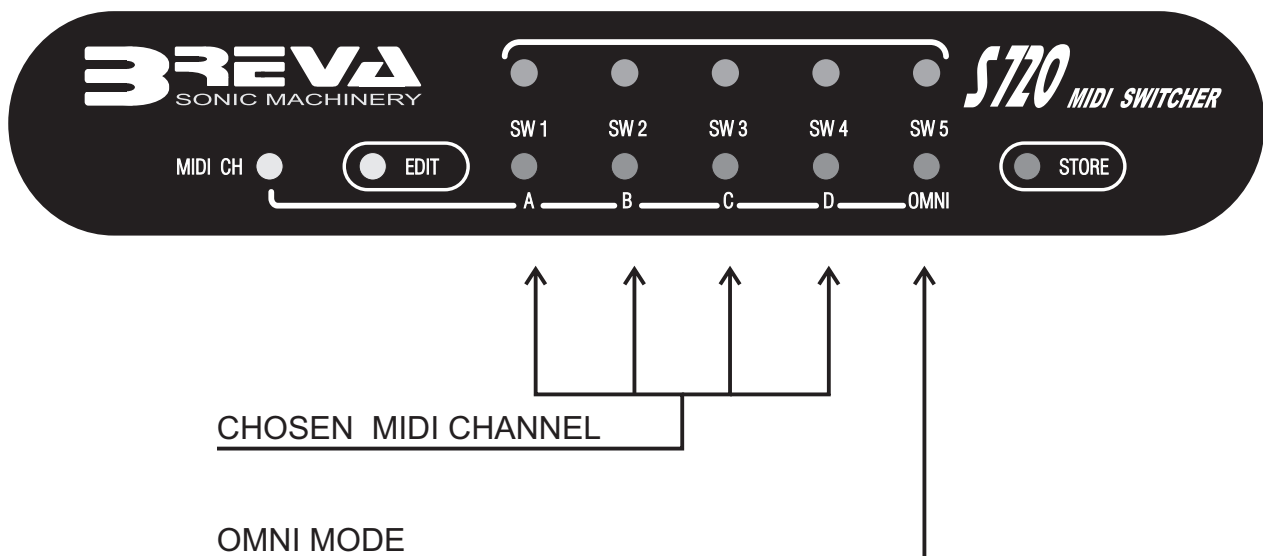

# POWER SUPPLY

S720 power can be supplied through the 2,5mm coaxial plug placed on the back panel or through a DIN 7 poles connector (with the MC7 cable, optional).

To obtain a correct functioning, S720 needs a continue 9V power and a current of at least 500mA.

It is possible to use the phantom connection also to supply other S720 in cascade, a MIDI pedal, or other device working with the same voltage: the only limit is the entity of the required current (mA).

In this case use a stronger power supplier.

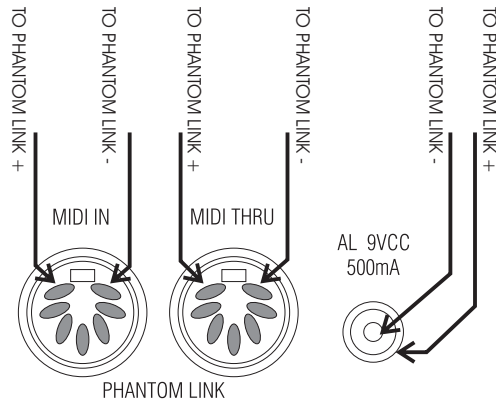

The two plugs: DIN 7 poles and coaxial 2,5mm are connected concerning the power supply (pin1 and pin7).

# Universal adaptor

This power supplier, included in S720 packages, is adaptable concerning the output voltage (VOLT), the polarity and the plug type.

In the package 6 plugs of different measures are supplied: use the one indicating 5.5 x 2.5 and insert it in the output plug coming from the power supplier according to the scheme beside.

Practically: looking at the symbol indicating the polarity with the negative pole in the center.



Insert the plug until the arrows meet.

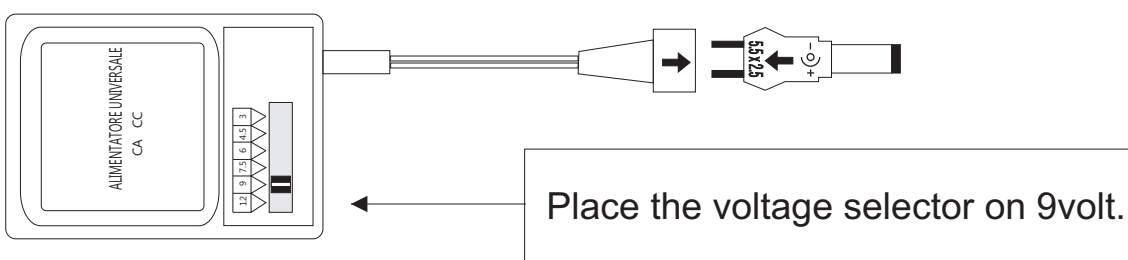
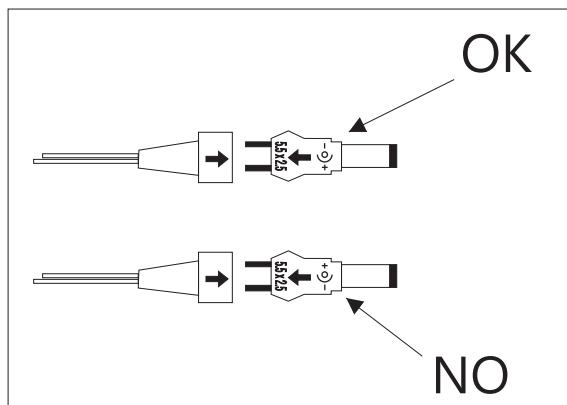

BREVA SONIC MACHINERY  
via Nino Bixio 2  
21040 VEDANO OLONA (VA)  
[www.breva.it](http://www.breva.it) [info@breva.it](mailto:info@breva.it)

